

A7

Receiving Card

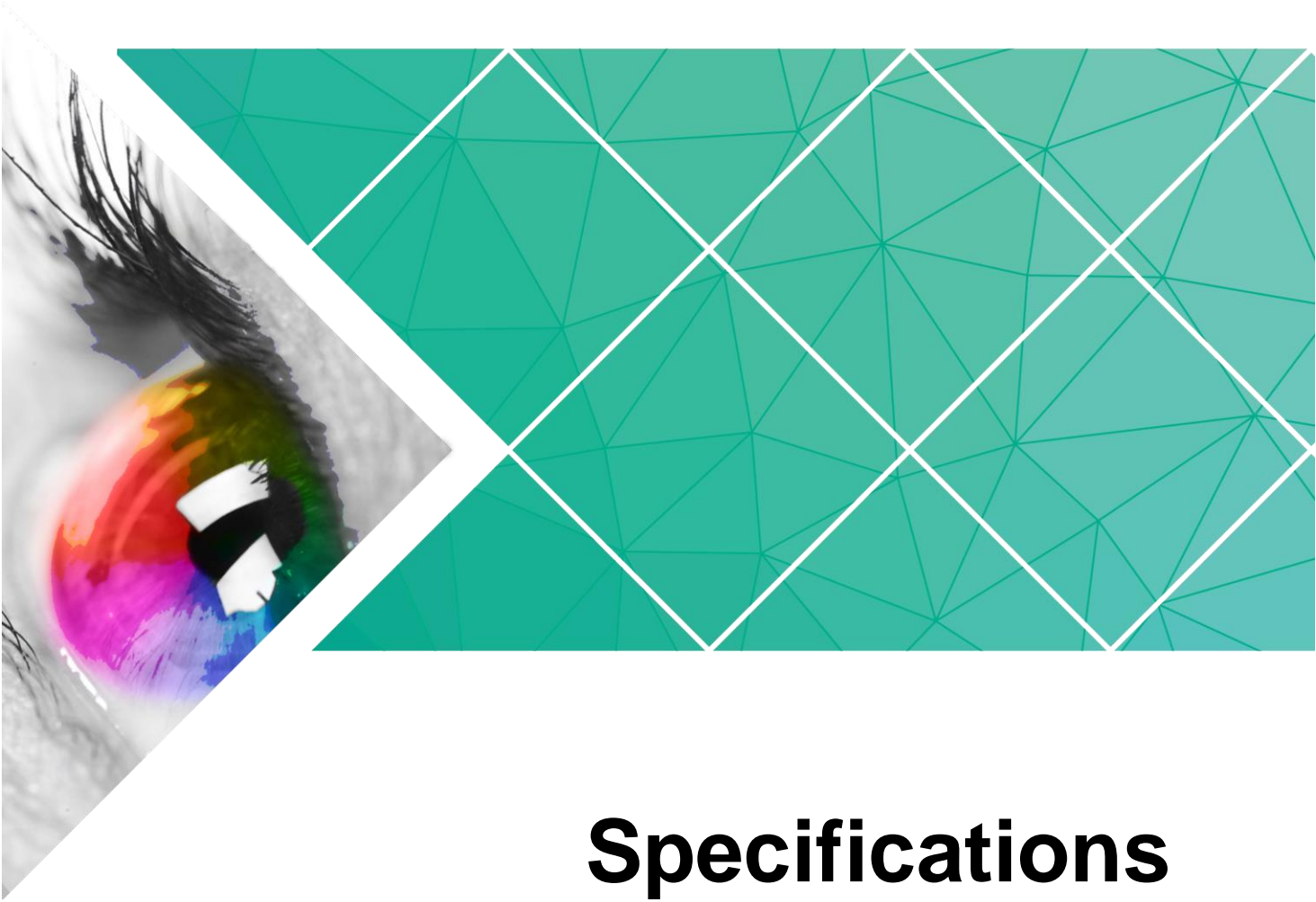

Specifications

Document Version: V1.2.0

Document Number: NS110100630

Copyright © 2018 Xi'an NovaStar Tech Co., Ltd. All Rights Reserved.

No part of this document may be copied, reproduced, extracted or transmitted in any form or by any means without the prior written consent of Xi'an NovaStar Tech Co., Ltd.

Trademark

 is a registered trademark of Xi'an NovaStar Tech Co., Ltd.

Statement

You are welcome to use the product of Xi'an NovaStar Tech Co., Ltd. (hereinafter referred to as NovaStar). This document is intended to help you understand and use the product. For accuracy and reliability, NovaStar may make improvements and/or changes to this document at any time and without notice. Any problem in use or any good suggestion, please contact us through ways provided in the document. We will do our utmost to solve the problems and adopt the suggestions after evaluation as soon as possible.

Change History

Version	Release Date	Description
V1.2.0	2018-08-10	Optimized the quick seam correction function.
V1.1.0	2018-07-10	Added the following functions: <ul style="list-style-type: none">• LVDS transmission (customized function).• Image rotation in 90° increments.
V1.0.1	2017-11-06	Changed the loading capacity of receiving card from 320x320 (PWM IC) to 512x256 (PWM IC).
V1.0.0	2017-06-30	The first version.

Contents

Change History	ii
1 Safety	1
2 Overview	2
3 Features	3
3.1 Improvement in Display Effect	3
3.2 Improvement in Maintainability	3
3.3 Improvement in Hardware Reliability	4
3.4 Improvement in Software Reliability	5
4 Hardware	6
4.1 Appearance	6
4.2 Dimensions	6
4.3 Indicators	7
4.4 Definition of Data Interface (Top)	8
4.4.1 32-Group Parallel Data	8
4.4.2 64-Group Serial Data	11
4.4.3 Extended Functions Design	13
5 Firmware Update	15
6 Applications	16
7 Specifications	17
A Abbreviation	18
B Terms	19

1 Safety

This chapter illustrates safety of the A7 receiving card to ensure the product's storage, transport, installation and use safety. Safety instructions are applicable to all personnel who contact or use the product. First of all, pay attention to following points.

- Read through the instructions.
- Retain all instructions.
- Comply with all instructions.

Storage and Transport Safety

- Pay attention to dust and water prevention.
- Avoid long-term direct sunlight.
- Do not place the product at a position near fire and heat.
- Do not place the product in an area containing explosive materials.
- Do not place the product in a strong electromagnetic environment.
- Place the product at a stable position to prevent damage or personal injury caused by dropping.
- Save the packing box and materials which will come in handy if you ever have to store and ship the product. For maximum protection during storage and shipping, repack the product as it was originally packed at the factory.

Installation and Use Safety

- Only trained professionals may install the product.
- Plugging and unplugging operations are prohibited when the power is on.
- Ensure safe grounding of the product.
- Always wear a wrist band and insulating gloves.
- Do not place the product in an area having frequent or strong shake.
- Perform dust removing regularly.
- Contact NovaStar for maintenance at any time, rather than have the product disassembled and maintained by non-professionals without authorization.
- Replace faulty parts only with the spare parts supplied by NovaStar.

2 Overview

A7 is a high-end receiving card developed by NovaStar, featuring small size and large loading capacity with a single card loading up to 512 x 256(PWM IC) pixels.

A7 supports pixel level brightness and chroma calibration by working with NovaLCT and NovaCLB to realize calibration on each pixel. It can effectively remove color difference and greatly improve LED display image consistency, presenting smoother images to users. In addition, it also supports image rotation in 90° increments, creating richer images and improving visual experiences.

Software and hardware designs of the A7 concern the user deployment as well as operating and maintenance scenarios, enabling easier deployment, more stable operating and more efficient maintenance.

Advanced hardware design:

- The small-size hardware design is applicable to scenarios of small cabinet space and small pixel pitch.
- The used DDR3 connectors have stable contact performance and good compatibility.

Useful software design:

- Support for LVDS transmission (Supported by dedicated firmware program).
- Support for smart module (Supported by dedicated firmware program).
- Support for quick seam correction.
- Support for 3D function.
- Support for auto module calibration.
- Support for Mapping function.
- Support for pre-stored image setting of the receiving card.
- Support for module Flash management.
- Supports monitoring voltage and temperature of itself without using other peripherals.
- Support for monitoring of Ethernet cable communication status (Supported by dedicated firmware program).
- Support for 5-pin LCD module.
- Support for image rotation in 90° increments.

3 Features

3.1 Improvement in Display Effect

Features	Description
Supporting pixel level brightness and chroma calibration	Working with NovaLCT and NovaCLB, A7 supports brightness and chroma calibration on each pixel.
Supporting image rotation in 90° increments (Calibration not supported after rotation)	On NovaLCT, the image on the screen can be set to rotate in the multiples of 90° (90° , 180° , 270° and 360°).
Supporting quick seam correction	Working with NovaLCT, A7 supports quick adjustment of bright and dark lines, which can remove the seams between modules and between cabinets.
Supporting 3D function	On NovaLCT or operation panel of controllers which support 3D function, you can enable 3D function and set the 3D parameters to make the LED screen display 3D effects.

3.2 Improvement in Maintainability

Features	Description
Supporting the smart module (Supported by dedicated firmware program)	<p>The smart module is composed of Flash and MCU. Flash could store calibration coefficients and module information. MCU could communicate with the receiving card to realize monitoring over temperature, voltage and wiring communication status for the module. Working with the driver chip, A7 supports open circuit detection on LED.</p> <p>The smart module could make monitoring unit smaller, requiring no independent monitoring card</p>

Features	Description
	and saving cabinet space.
Supporting LVDS transmission (Supported by dedicated firmware program)	The transmission mode of low-voltage differential signaling (LVDS) is used, which reduces the number of data cables that connect the receiving card's HUB board to the module, increases the transmission distance, improves the signal transmission quality, and better stabilizes the image output.
Supporting auto module calibration	After the module has been replaced, the receiving card can automatically read the new module ID and calibration coefficient which could be saved to calibration system files.
Supporting Mapping function	Enable the Mapping function on NovaLCT, then the target cabinet will display the cabinet number and Ethernet port information, and the user could get the receiving card's location and wiring route.
Supporting setting of images pre-stored of the receiving card	On NovaLCT, the specified images could be set as the screen startup image and images used when the Ethernet cable is disconnected or no video source signal is available.
Supporting module Flash management	On NovaLCT, lamp panel Flash could be managed.
Supporting monitoring voltage and temperature of itself	The voltage and temperature of the receiving card itself can be monitored without using other peripherals. The monitoring data can be checked on NovaLCT.
Supporting LCD module	Supports NovaStar's general 5-pin LCD module. The LCD module is connected to the HUB board to display temperature, voltage, single operating time and total operating time of the receiving card.
Support one-click application of calibration coefficient in module Flash	In the event of network outage, hold down the self-test button to read the calibration coefficient in module Flash back to the receiving card.

3.3 Improvement in Hardware Reliability

Features	Description
Supporting dual-card backup	In the high-reliability environment, single HUB board could be populated with two A7 receiving cards. In case that the main receiving card fails, the standby one will serve in a timely manner to ensure normal operation of the display.
Supporting dual-power	Two power supplies could be simultaneously

Features	Description
backup detection	connected, and operating status of the power supplies could be detected.
Supporting loop backup	HUB's Ethernet port improves the reliability for the serial connection of the receiving card through main and standby redundant mechanism. Among the main and standby serial connection lines, if one fails, the other will begin to work to ensure the normal operation of the display.

3.4 Improvement in Software Reliability

Features	Description
Supporting readback of firmware version	On NovaLCT, the firmware versions of the receiving card can be read back.
Supporting dual-backup and restoring of the calibration coefficient	Calibration coefficients could be saved to both the factory area and application area at the same time. Calibration coefficients in the factory area is default as the delivery value, while the calibration coefficient in the application area could be modified or be restored to the factory reset by the user on NovaLCT.
Supporting readback of configuration file	<ul style="list-style-type: none"> • On NovaLCT, the receiving card configuration parameters can be backed up to the receiving card. • On NovaLCT, the receiving card configuration parameters can be read back.

4 Hardware

4.1 Appearance

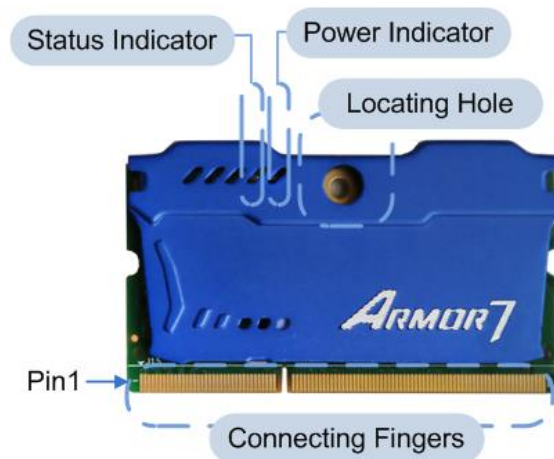

Product images provided in this file are for reference only, and the actual products shall prevail.

Models of DDR3 connectors (connecting fingers) and receptacle used by A7 are shown in table Table 4-1.

Table 4-1 Model of high-density connector

Type	Brand	Material Code
DDR3	/	/
Receptacle	Tyco	2-2013289-1

4.2 Dimensions

Board thickness is not greater than 1.5 mm, and the total thickness (board thickness + thickness of both front panel and back panel) is not greater than 6.5 mm.

Unit of the dimension chart is “mm”. Ground connection is enabled for location hole (GND).

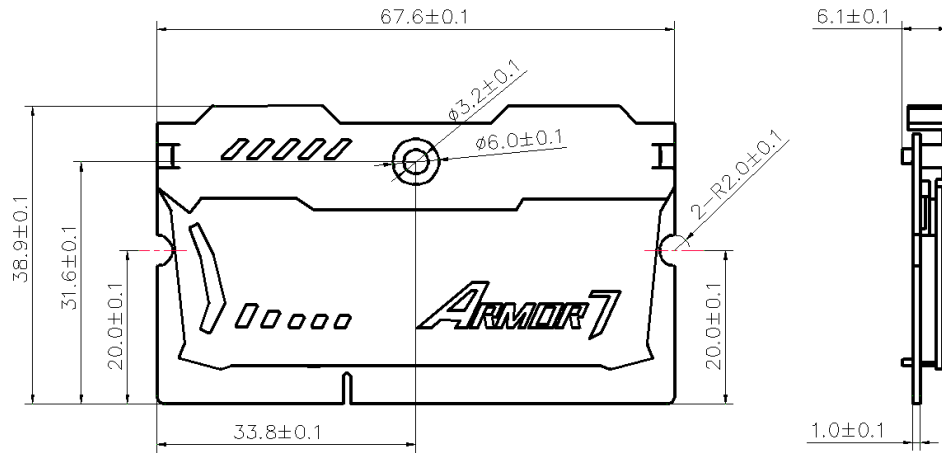

4.3 Indicators

Indicator	Status	Description
Status indicator (green)	Flashing every other 1s.	The receiving card works normally, Ethernet cable connection is normal, and video source input is available.
	Flashing every other 3s.	The receiving card works normally, while the Ethernet cable connection is abnormal.
	Rapidly flashing for 3 times every other 3s.	The receiving card works normally, Ethernet cable connection is normal, while no video source input is available.
	Rapidly flashing every other 0.5s.	Program loading fails in normal operating state, coming to the backup operating state.
	Rapidly flashing for 8 times every other 1s.	The receiving card is in the Ethernet port backup status and the backup is effective.
Power indicator (red)	Always on	It is always on after the power is on.

4.4 Definition of Data Interface (Top)

4.4.1 32-Group Parallel Data

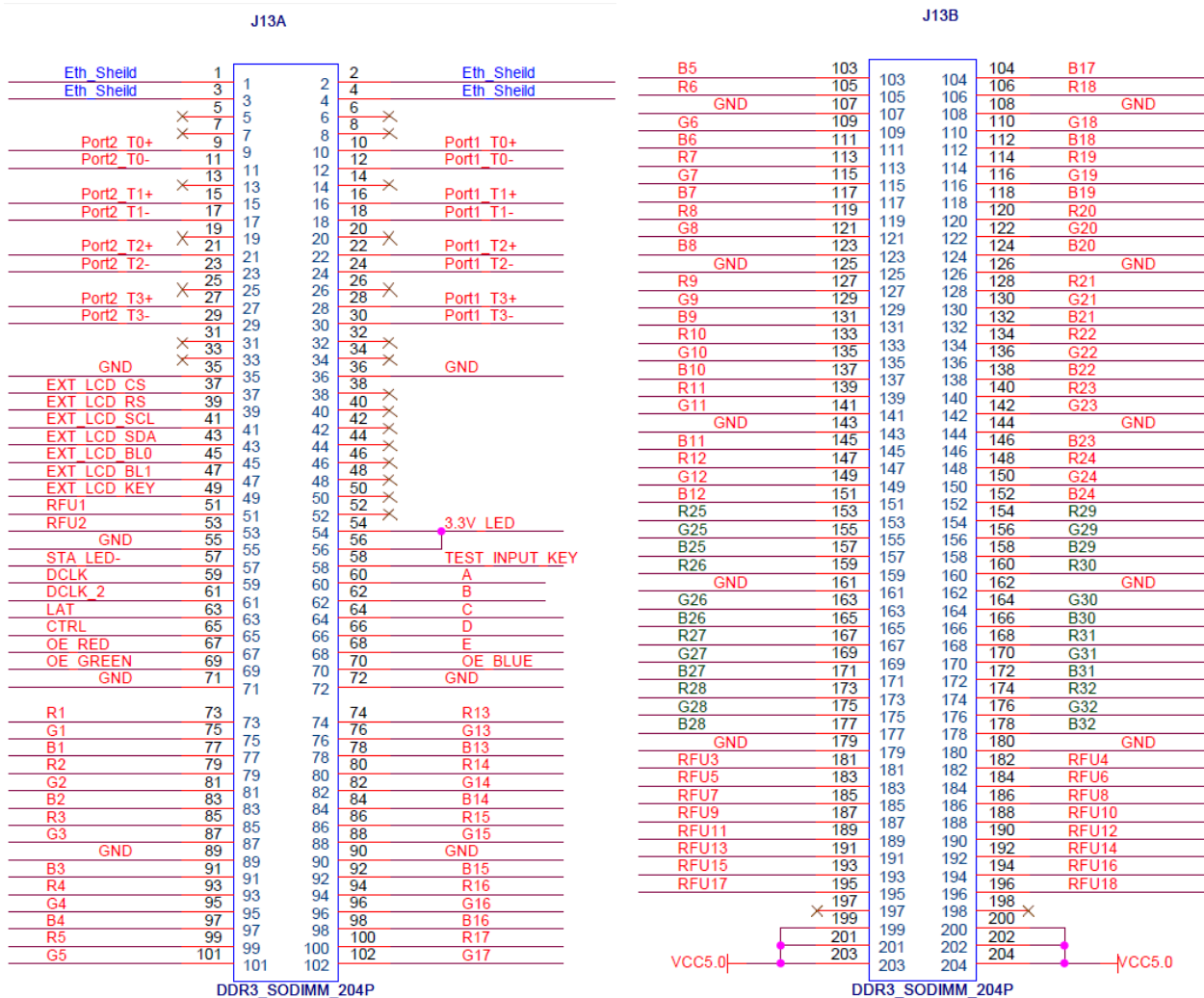

J13A							
	Shield grounding	Eth_Sheild	1	2	Eth_Sheild	Shield grounding	
	Shield grounding	Eth_Sheild	3	4	Eth_Sheild	Shield grounding	
Gigabit Ethernet port		NC	5	6	NC		Gigabit Ethernet port
		NC	7	8	NC		
	/	Port2_T0+	9	10	Port1_T0+	/	
	/	Port2_T0-	11	12	Port1_T0-	/	
		NC	13	14	NC		
	/	Port2_T1+	15	16	Port1_T1+	/	
	/	Port2_T1-	17	18	Port1_T1-	/	
		NC	19	20	NC		
	/	Port2_T2+	21	22	Port1_T2+	/	
	/	Port2_T2-	23	24	Port1_T2-	/	
		NC	25	26	NC		
	/	Port2_T3+	27	28	Port1_T3+	/	
/	Port2_T3-	29	30	Port1_T3-	/		
	NC	31	32	NC			

J13A							
		NC	33	34	NC		
		GND	35	36	GND		
LCD	CS signal of LCD	EXT_LCD_CS	37	38	NC		
	RS signal of LCD	EXT_LCD_RS	39	40	NC		
	Clock signal of LCD	EXT_LCD_SCL	41	42	NC		
	Data signal of LCD	EXT_LCD_SDA	43	44	NC		
	Backlight signal 1 of LCD	EXT_LCD_BL0	45	46	NC		
	Backlight signal 2 of LCD	EXT_LCD_BL1	47	48	NC		
	LCD control button	EXT_LCD_KEY	49	50	NC		
Note 4	/	RFU1	51	52	NC		
	/	RFU2	53	54	3.3V_LED	Assist output applies 3.3V power.	
		GND	55	56			
Note 2	Operating indicator	STA_LED-	57	58	TEST_INPUT_KEY	Test button	
	Shift clock output in the first route	DCLK	59	60	A	Line coding signal	
	Shift clock output in the second route	DCLK_2	61	62	B		
	Locking of the signal	LAT	63	64	C		
	Afterglow control signal	CTRL	65	66	D		
Note 3	Display enabled	OE_RED	67	68	E		
	Display enabled	OE_GREEN	69	70	OE_BLUE	Display enabled	Note 3
		GND	71	72	GND		
	/	R1	73	74	R13	/	
	/	G1	75	76	G13	/	
	/	B1	77	78	B13	/	
	/	R2	79	80	R14	/	
	/	G2	81	82	G14	/	
	/	B2	83	84	B14	/	
	/	R3	85	86	R15	/	
	/	G3	87	88	G15	/	
		GND	89	90	GND		
	/	B3	91	92	B15	/	
	/	R4	93	94	R16	/	
	/	G4	95	96	G16	/	
	/	B4	97	98	B16	/	
	/	R5	99	100	R17	/	
	/	G5	101	102	G17	/	

J13B							
	/	B5	103	104	B17	/	
	/	R6	105	106	R18	/	
		GND	107	108	GND		
	/	G6	109	110	G18	/	
	/	B6	111	112	B18	/	
	/	R7	113	114	R19	/	
	/	G7	115	116	G19	/	
	/	B7	117	118	B19	/	
	/	R8	119	120	R20	/	
	/	G8	121	122	G20	/	
	/	B8	123	124	B20	/	
		GND	125	126	GND		
	/	R9	127	128	R21	/	
	/	G9	129	130	G21	/	

J13B							
	/	B9	131	132	B21	/	
	/	R10	133	134	R22	/	
	/	G10	135	136	G22	/	
	/	B10	137	138	B22	/	
	/	R11	139	140	R23	/	
	/	G11	141	142	G23	/	
		GND	143	144	GND		
	/	B11	145	146	B23	/	
	/	R12	147	148	R24	/	
	/	G12	149	150	G24	/	
	/	B12	151	152	B24	/	
	/	R25	153	154	R29	/	
	/	G25	155	156	G29	/	
	/	B25	157	158	B29	/	
	/	R26	159	160	R30	/	
		GND	161	162	GND		
	/	G26	163	164	G30	/	
	/	B26	165	166	B30	/	
	/	R27	167	168	R31	/	
	/	G27	169	170	G31	/	
	/	B27	171	172	B31	/	
	/	R28	173	174	R32	/	
	/	G28	175	176	G32	/	
	/	B28	177	178	B32	/	
		GND	179	180	GND		
Note 4	/	RFU3	181	182	RFU4	/	Note 4
	/	RFU5	183	184	RFU6	/	
	/	RFU7	185	186	RFU8	/	
	/	RFU9	187	188	RFU10	/	
	/	RFU11	189	190	RFU12	/	
	/	RFU13	191	192	RFU14	/	
	/	RFU15	193	194	RFU16	/	
	/	RFU17	195	196	RFU18	/	
		NC	197	198	NC		
Note 1		VCC	199	200	VCC		Note 1
		VCC	201	202	VCC		
		VCC	203	204	VCC		

4.4.2 64-Group Serial Data

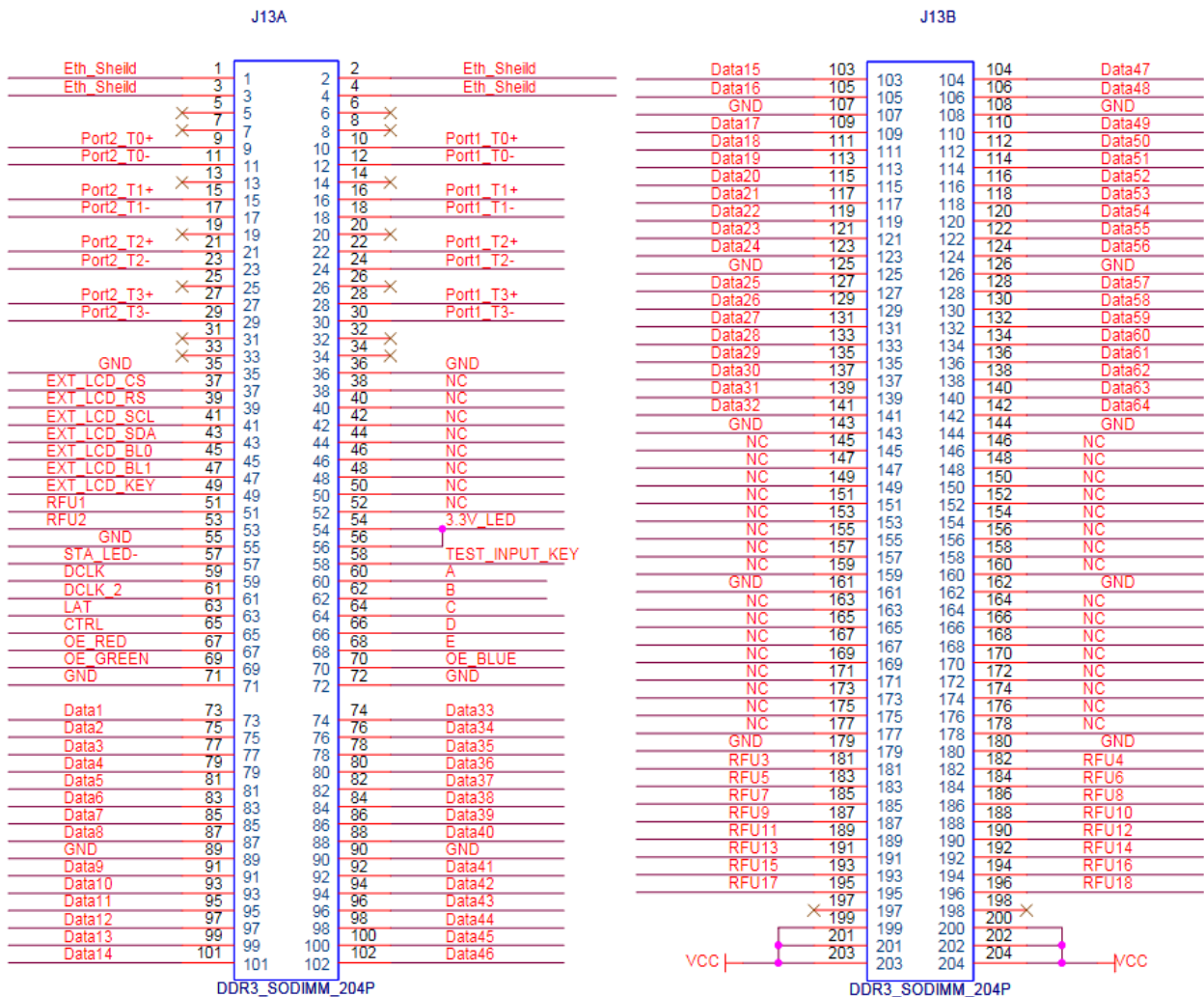

J13A						
	Shield grounding	Eth_Sheild	1	2	Eth_Sheild	Shield grounding
	Shield grounding	Eth_Sheild	3	4	Eth_Sheild	Shield grounding
Gigabit Ethernet port		NC	5	6	NC	
		NC	7	8	NC	
	/	Port2_T0+	9	10	Port1_T0+	/
	/	Port2_T0-	11	12	Port1_T0-	/
		NC	13	14	NC	
	/	Port2_T1+	15	16	Port1_T1+	/
	/	Port2_T1-	17	18	Port1_T1-	/
		NC	19	20	NC	
	/	Port2_T2+	21	22	Port1_T2+	/
	/	Port2_T2-	23	24	Port1_T2-	/
	GND	25	26	GND		
/	Port2_T3+	27	28	Port1_T3+	/	
/	Port2_T3-	29	30	Port1_T3-	/	
	NC	31	32	NC		
	NC	33	34	NC		
	GND	35	36	GND		
LCD	CS signal of LCD	EXT_LCD_CS	37	38	NC	

J13A							
	RS signal of LCD	EXT_LCD_RS	39	40	NC		
	Clock signal of LCD	EXT_LCD_SCL	41	42	NC		
	Data signal of LCD	EXT_LCD_SDA	43	44	NC		
	Backlight signal 1 of LCD	EXT_LCD_BL0	45	46	NC		
	Backlight signal 2 of LCD	EXT_LCD_BL1	47	48	NC		
	LCD control button	EXT_LCD_KEY	49	50	NC		
Note 4	/	RFU1	51	52	NC		
	/	RFU2	53	54	3.3V_LED	Auxiliary output applies 3.3V power.	
		GND	55	56			
Note 2	Operating indicator	STA_LED-	57	58	TEST_INPUT_KEY	Test button	
	Shift clock output in the first route	DCLK	59	60	A	Line coding signal	
	Shift clock output in the second route	DCLK_2	61	62	B	Line coding signal	
	Locking of the signal output	LAT	63	64	C	Line coding signal	
	Afterglow control signal	CTRL	65	66	D	Line coding signal	
Note 3	Display enabled	OE_RED	67	68	E	Line coding signal	
	Display enabled	OE_GREEN	69	70	OE_BLUE	Display enabled	Note 3
		GND	71	72	GND		
	/	Data1	73	74	Data33	/	
	/	Data2	75	76	Data34	/	
	/	Data3	77	78	Data35	/	
	/	Data4	79	80	Data36	/	
	/	Data5	81	82	Data37	/	
	/	Data6	83	84	Data38	/	
	/	Data7	85	86	Data39	/	
	/	Data8	87	88	Data40	/	
		GND	89	90	GND		
	/	Data9	91	92	Data41	/	
	/	Data10	93	94	Data42	/	
	/	Data11	95	96	Data43	/	
	/	Data12	97	98	Data44	/	
	/	Data13	99	100	Data45	/	
	/	Data14	101	102	Data46	/	

J13B							
	/	Data15	103	104	Data47	/	
	/	Data16	105	106	Data48	/	
		GND	107	108	GND		
	/	Data17	109	110	Data49	/	
	/	Data18	111	112	Data50	/	
	/	Data19	113	114	Data51	/	
	/	Data20	115	116	Data52	/	
	/	Data21	117	118	Data53	/	
	/	Data22	119	120	Data54	/	
	/	Data23	121	122	Data55	/	
	/	Data24	123	124	Data56	/	
		GND	125	126	GND		
	/	Data25	127	128	Data57	/	
	/	Data26	129	130	Data58	/	
	/	Data27	131	132	Data59	/	

J13B							
	/	Data28	133	134	Data60	/	
	/	Data29	135	136	Data61	/	
	/	Data30	137	138	Data62	/	
	/	Data31	139	140	Data63	/	
	/	Data32	141	142	Data64	/	
		GND	143	144	GND		
		NC	145	146	NC		
		NC	147	148	NC		
		NC	149	150	NC		
		NC	151	152	NC		
		NC	153	154	NC		
		NC	155	156	NC		
		NC	157	158	NC		
		NC	159	160	NC		
		GND	161	162	GND		
		NC	163	164	NC		
		NC	165	166	NC		
		NC	167	168	NC		
		NC	169	170	NC		
		NC	171	172	NC		
		NC	173	174	NC		
		NC	175	176	NC		
		NC	177	178	NC		
		GND	179	180	GND		
Note 4	/	RFU3	181	182	RFU4	/	Note 4
	/	RFU5	183	184	RFU6	/	
	/	RFU7	185	186	RFU8	/	
	/	RFU9	187	188	RFU10	/	
	/	RFU11	189	190	RFU12	/	
	/	RFU13	191	192	RFU14	/	
	/	RFU15	193	194	RFU16	/	
		RFU17	195	196	RFU18	/	
		NC	197	198	NC		
Note 1		VCC	199	200	VCC		Note 1
		VCC	201	202	VCC		
		VCC	203	204	VCC		

Note 1. Voltage ranging from 3.3V to 5.5V is recommended for input power (VCC).

Note 2. Operating indicator that meets low level is valid.

Note 3. OE_RED, OE_GREEN and OE_BLUE are display enabled pins. In case that OE_RGB are not controlled separately, OE_RED is applied. While PWM chip is used, GCLK signal is enabled.

Note 4. RFU1–18 are the reserved extended function interfaces. Please refer to “4.4.3 Extended Functions Design”.

4.4.3 Extended Functions Design

Extended Functions Description			
Expandable Interface	Recommended Smart Module Interface	Recommended Module Flash Interface	Description
RFU1	Reserved	Reserved	Reserved pin connected to MCU
RFU2	Reserved	Reserved	Reserved pin connected to MCU

Extended Functions Description			
RFU3	HUB_CODE0	HUB_CODE0	Flash control interface 1
RFU4	HUB_SPI_CLK	HUB_SPI_CLK	Clock signal of the serial interface
RFU5	HUB_CODE1	HUB_CODE1	Flash control interface 2
RFU6	HUB_SPI_CS	HUB_SPI_CS	CS signal of the serial interface
RFU7	HUB_CODE2	HUB_CODE2	Flash control interface 3
RFU8	/	HUB_SPI_MOSI	Module Flash storage data input
	HUB_UART_TX	/	TX signal of the smart module
RFU9	HUB_CODE3	HUB_CODE3	Flash control interface 4
RFU10	/	HUB_SPI_MISO	Flash storage data output of the lamp panel
	HUB_UART_RX	/	RX signal of the smart module
RFU11	HUB_H164_CSD	HUB_H164_CSD	74HC164 data signal
RFU12	POWER_STA1	POWER_STA1	Dual-power detection signal 1
RFU13	HUB_H164_CLK	HUB_H164_CLK	74HC164 Clock signal
RFU14	POWER_STA2	POWER_STA2	Dual-power detection signal 2
RFU15	MS_ID	MS_ID	Dual-card backup identification signal
RFU16	/	/	/
RFU17	MS_DATA	MS_DATA	Dual-card backup connection signal
RFU18	HUB_CODE4	HUB_CODE4	Flash control interface 5.

Note: The RFU8 and RFU10 are signal multiplex extension interfaces. You can select only one interface from either the **Recommended Smart Module Interface** or the **Recommended Module Flash Interface** at the same time.

5 Firmware Update

- Step 1 Visit www.novastar.tech to download the firmware update package and save it to PC.
- Step 2 Run NovaLCT and choose **User > Advanced Synchronous System User Login** to log in.
- Step 3 Type the secret code "**admin**" to enter the program loading page.
- Step 4 Click **Browse** to select the program (the firmware update package you saved on PC) path and then click **Update**.
- Step 5 Click **Refresh** to check current hardware version information.

6 Applications

A7 is applied to LED display synchronous system which is generally composed of the LED display, HUB board, receiving card, video controller and controller peripheral. The receiving card is connected to the display over a HUB board.

Synchronous system requires connecting a computer to display the computer's images and texts on the LED screen. Structure of the synchronous system is as shown in the following figure.

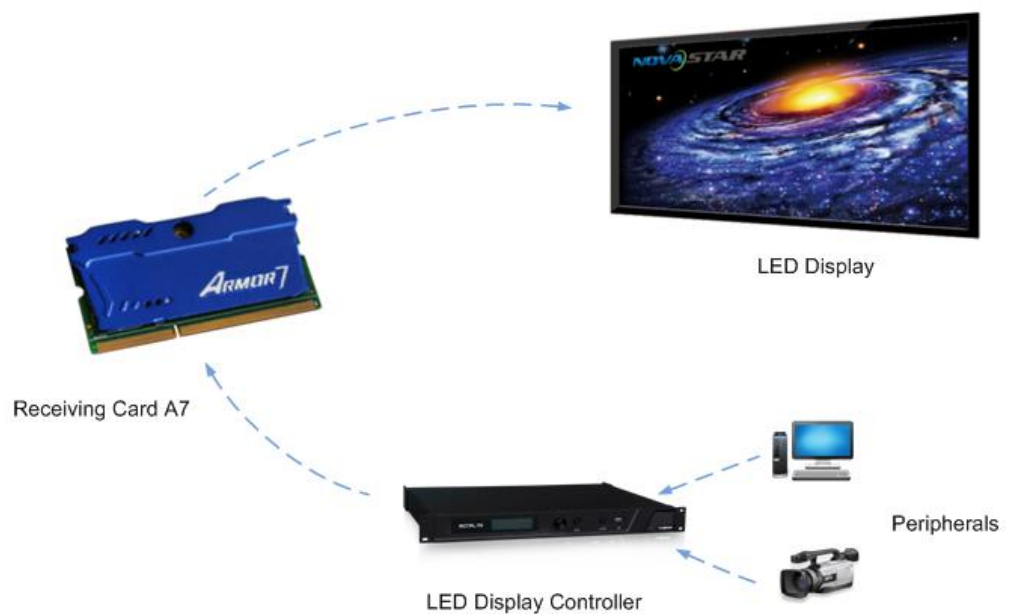

7 Specifications

Input voltage	DC 3.3 V–5.5 V
Rated current	0.5 A
Rated power consumption	2.5 W
Operating temperature	-20°C–70°C
Storage temperature	-25°C–125°C
Operating humidity	10%RH–90%RH
Dimensions	67.6 mm × 38.9 mm × 6.1 mm
Net weight	9.9 g
Certifications	RoHS
Packing	An antistatic bag and anti-collision foam are prepared for each receiving card. Dimensions of the packing box: 378 mm × 190 mm × 120 mm, each of 40 receiving cards.

A Abbreviation

F

FPGA Field-Programmable Gate Array

L

LED Light Emitting Diode

M

MCU Microcontroller Unit

R

RCFG Receiving Card Configuration

B Terms

Calibration coefficient

Calibration system generates a group of values for each LED lamp, including information about brightness and chroma. After display calibration, the calibration values of each lamp are just the calibration coefficient.

Smart module

The smart module is composed of Flash and MCU.

Flash could store calibration coefficients and lamp panel information. MCU could communicate with the receiving card to realize monitoring over temperature, voltage and wiring communication status, Working with the driver chip, A7 supports open circuit detection on LED.

The smart module could make monitoring unit smaller, requiring no independent monitoring card and saving cabinet space.

Mapping

After the Mapping function is enabled on NovaLCT, the target cabinet will display the cabinet number and Ethernet port information, and the user could get the receiving card's location and wiring route.